

EDGE

By Hammel

40007-E3

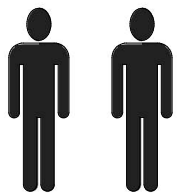
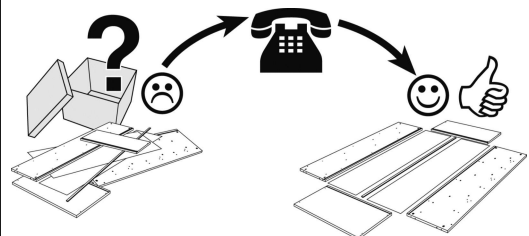
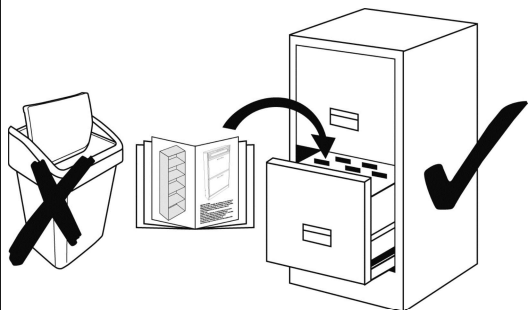

PZ2

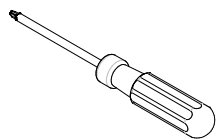

T1

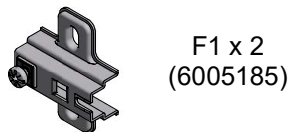

F1 x 2
(6005185)

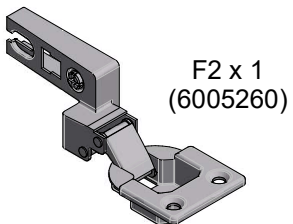

F2 x 1
(6005260)

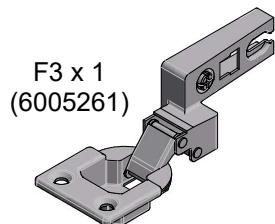

F3 x 1
(6005261)

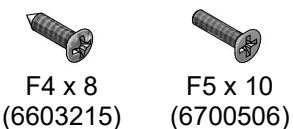

F4 x 8
(6603215)

F5 x 10
(6700506)

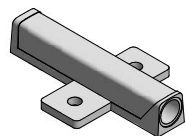

F6 x 1
(6005030)

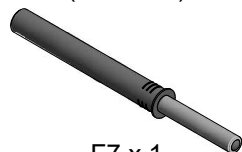

F7 x 1
(6005025)



T1 x 1
(6200333)

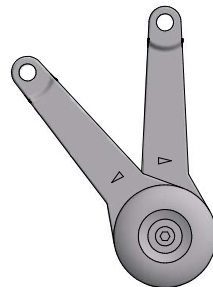

F8
(6200330)



F9
(6200331)



F10
(6200332)

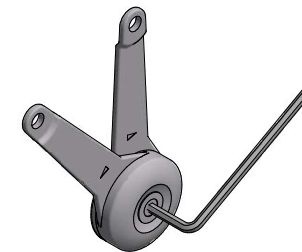

40007-E3-P1 /11

Meget vigtigt! Se nøje på side 2 og drej F8 fittingen til korrekt position.
Very important! Look at page 2 and turn the F8 bracket into correct position.
Sehr wichtig! Schauen Sie auf Seite 2 und drehen Sie der F8 Beschlag in die richtige Position.
Viktigt! Se sida 2 och var uppmärksam på att montera F8 i korrekt position.

F8 strammes eller løsnes med T1 nøglen.
Tighten or loosen the F8 bracket with a T1 wrench.
Ziehen oder lösen der F8 Beschlag mit einem T1-Schraubenschlüssel.
F8 vrids åt eller öppnas med T1 nyckeln.

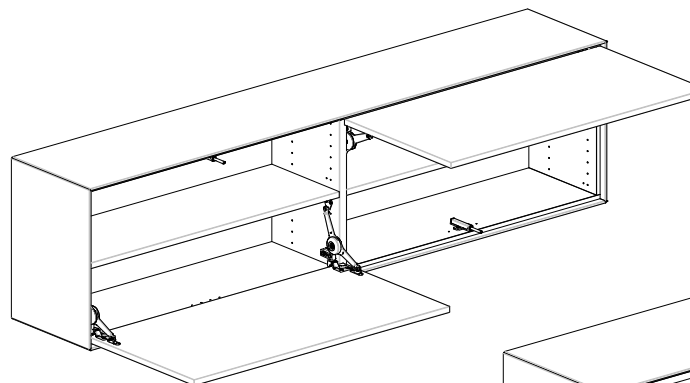

Høj klap: 2 stk F8
High flap: 2 pcs. of F8
Hohe Klappe: 2 Stck. F8
Stor lucka: 2 st F8

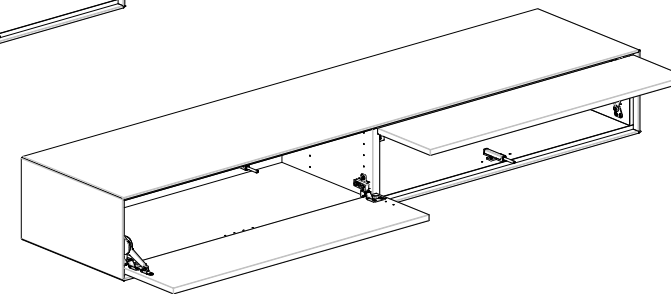

Lav klap: 1 stk F8
Low flap: 1 pc. of F8
Kleine Klappe: 1 Stck. F8
Liten lucka: 1 st F8

Side 2 gælder for både høj og lav klap.
Page 2 applies for both high and low flap.
Seite 2 gilt für allen Klappen.
Sida 2 gäller för både stor och liten lucka.

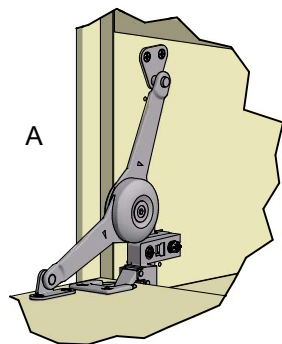
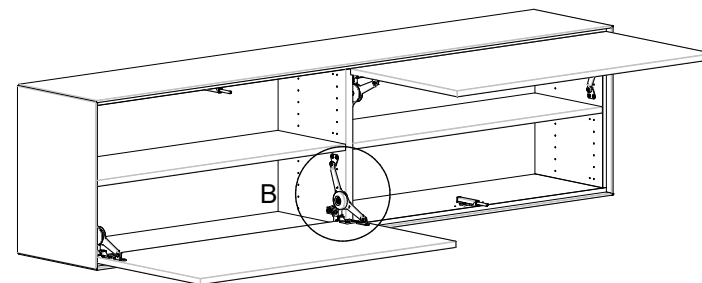
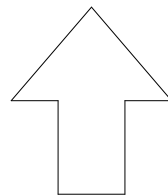
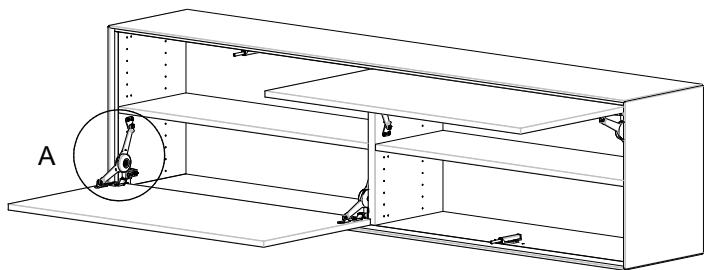

När klap lukkes opad.
When flap closes upwards.
Wenn die Klappe nach oben schließt.
När luckan stängs nerifrån och upp.

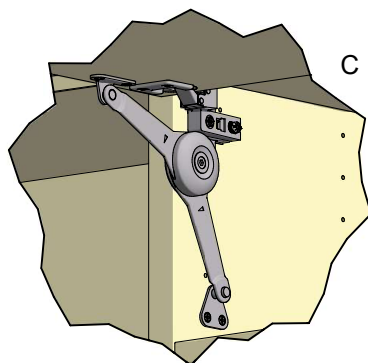
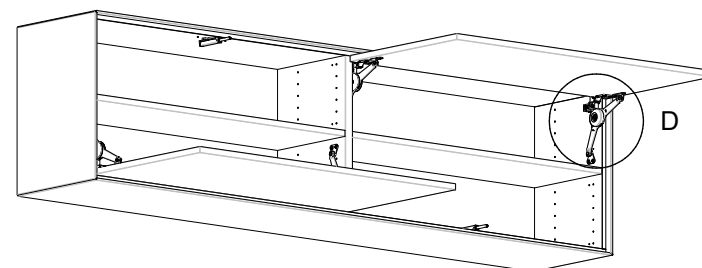
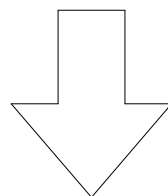
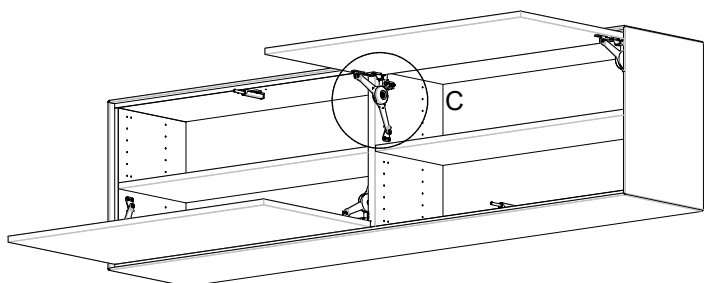
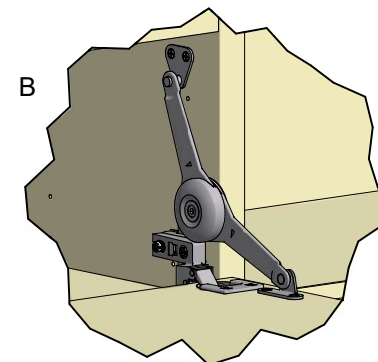

När klap lukkes nedad.
When flap closes downwards.
Wenn die Klappe nach unten schließt.
När luckan stängs uppifrån och ned.

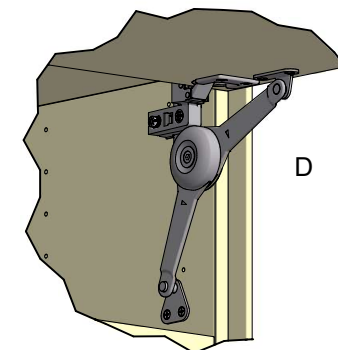

Eksempel med høje klapper.
 Example with high flaps.
 Beispiel: Hohe Klappen.
 Exempel med en hög (större) lucka.

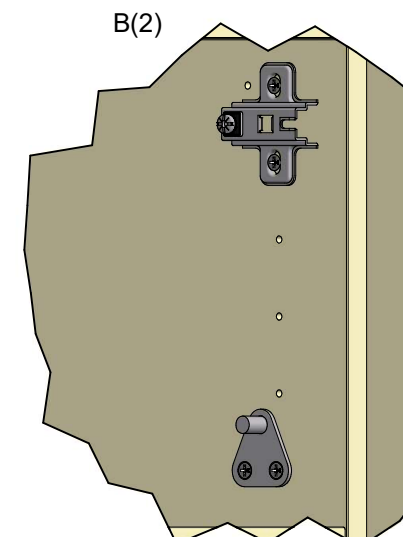
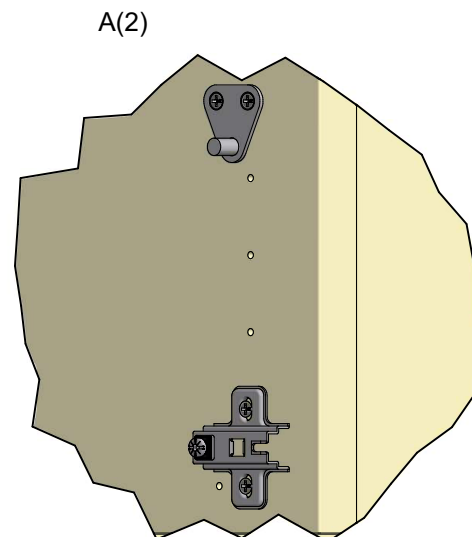
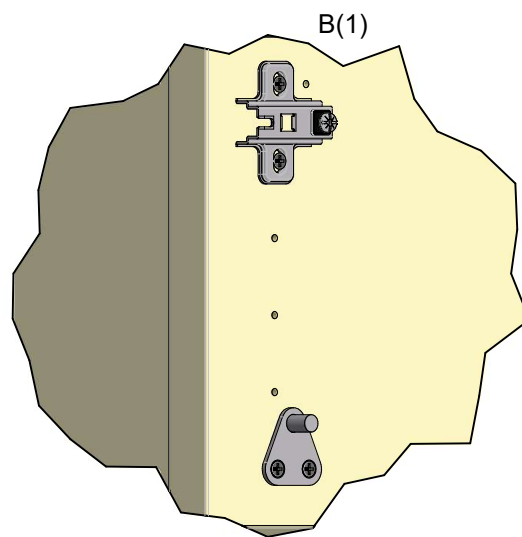
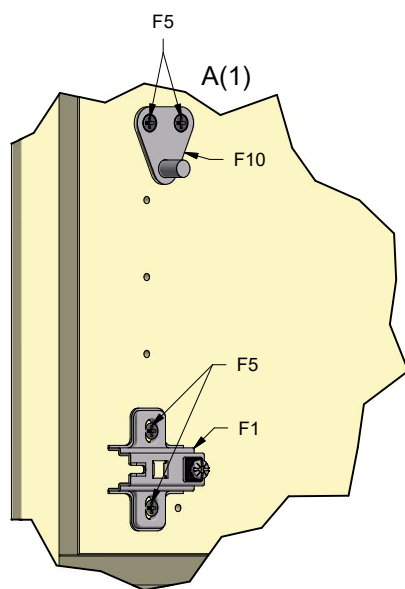
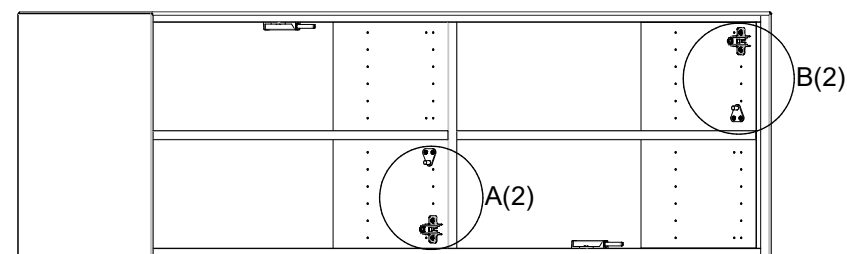
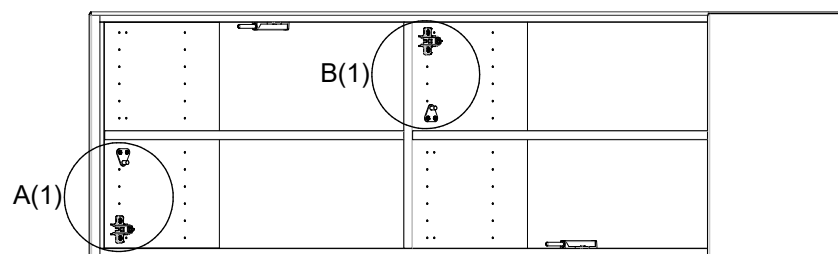
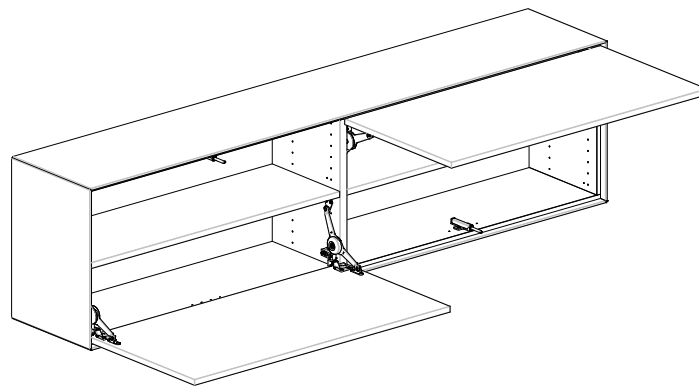

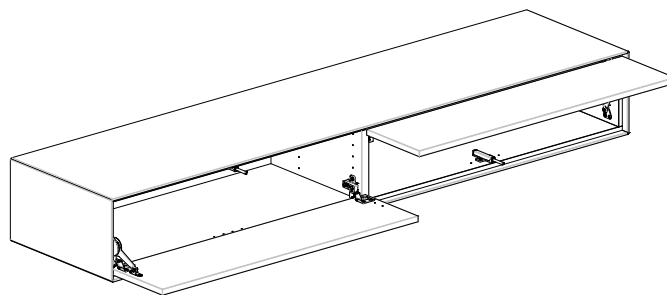

Eksempel med lave klapper.
Example with low flaps.
Beispiel: Kleine Klappen
Exempel med en mindre lucka.

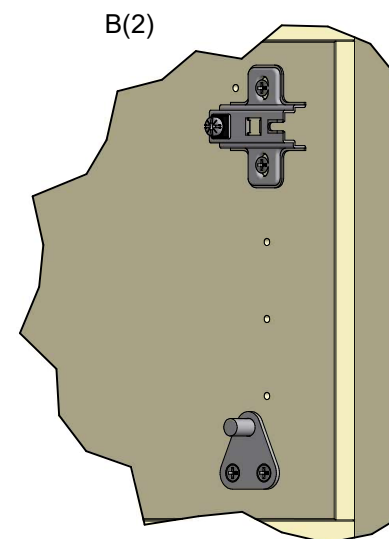
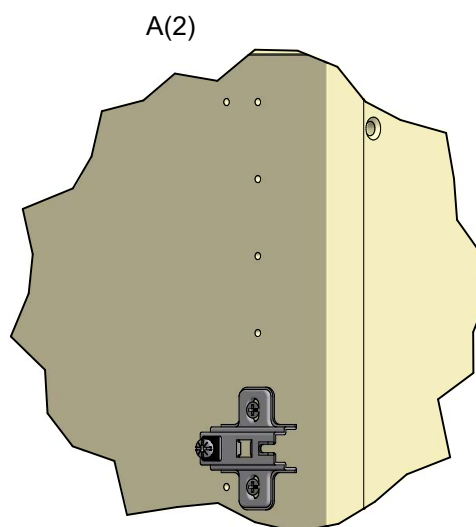
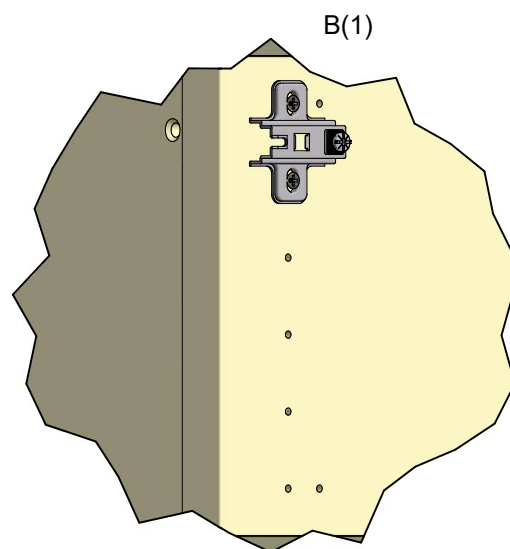
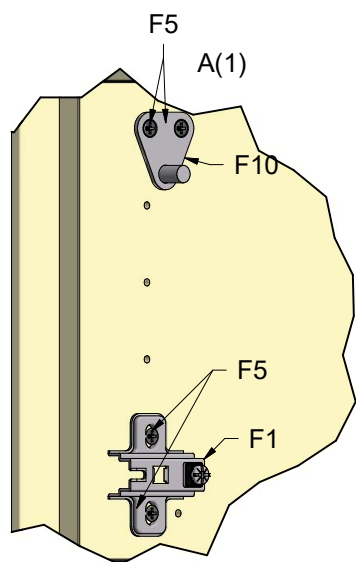
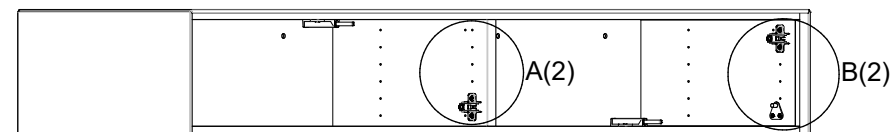
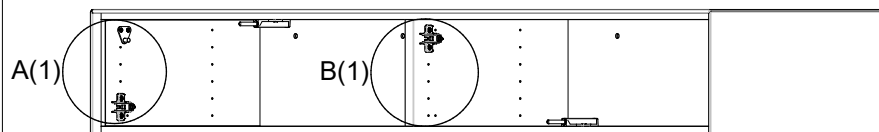

3

40007-E3-P5 /11

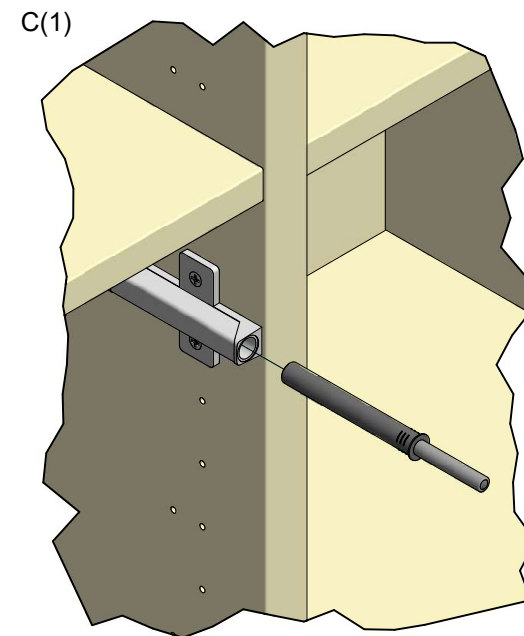
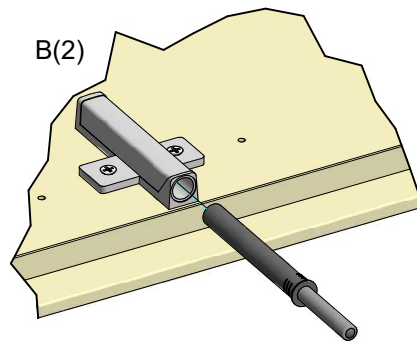
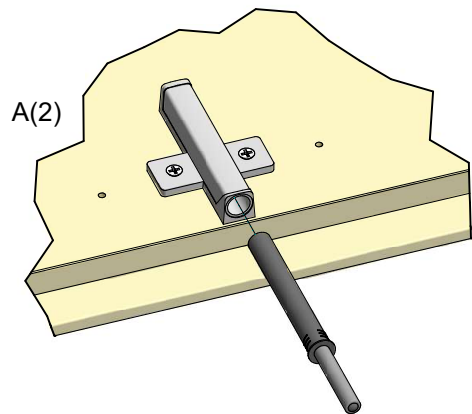
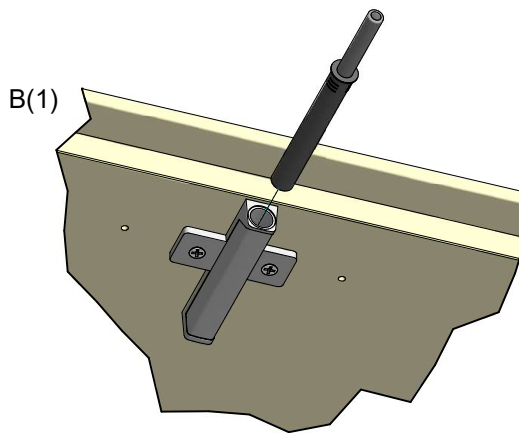
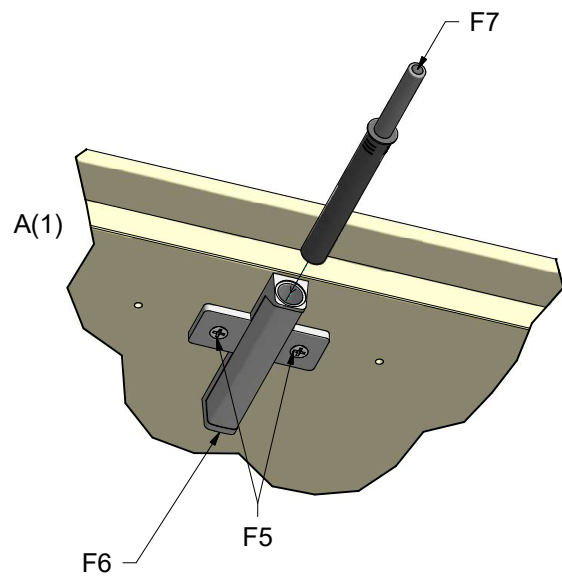
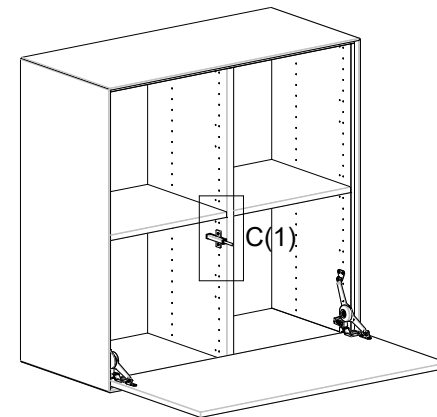
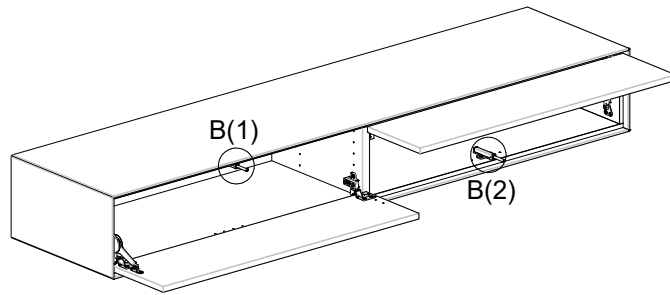
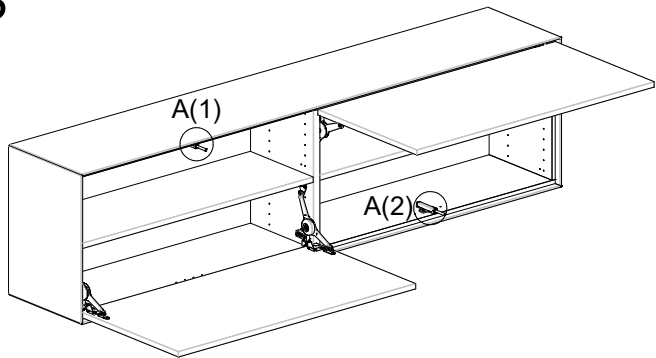

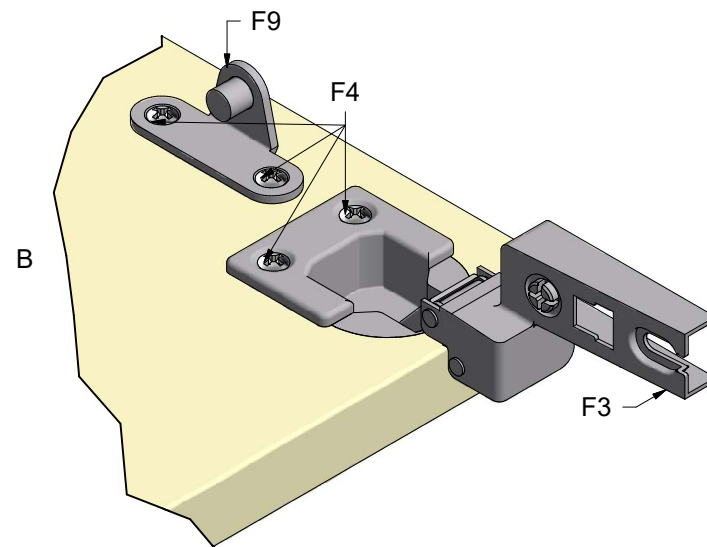
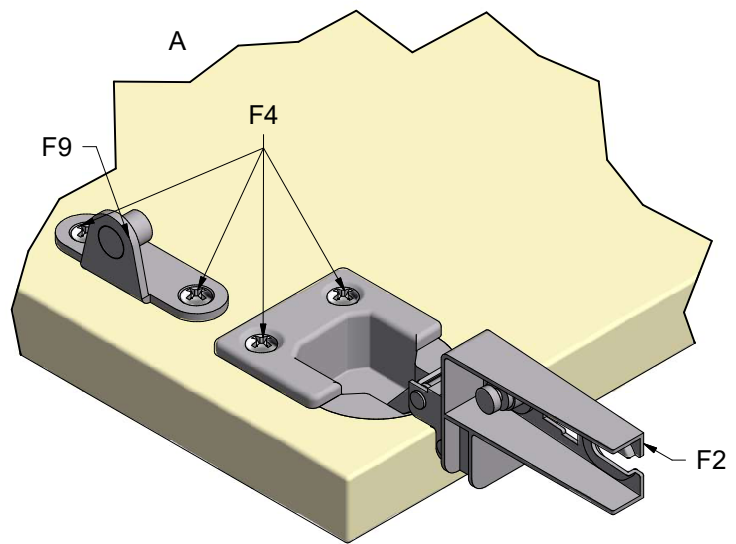
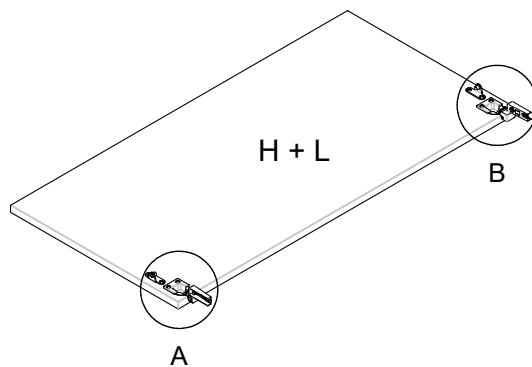
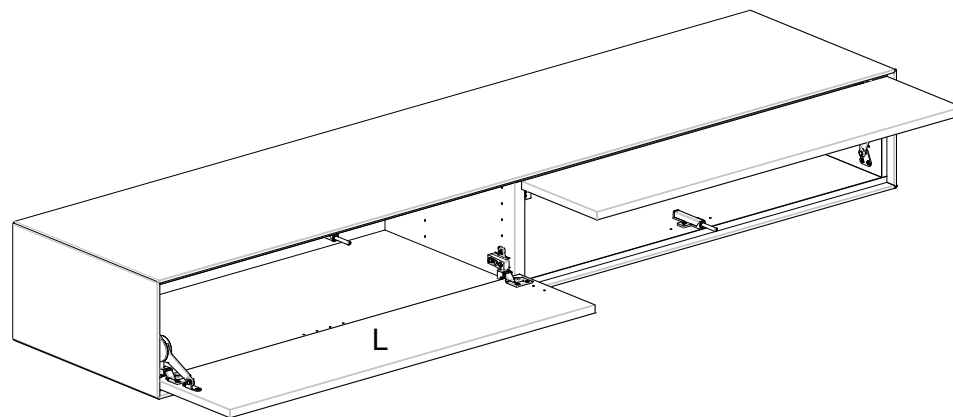
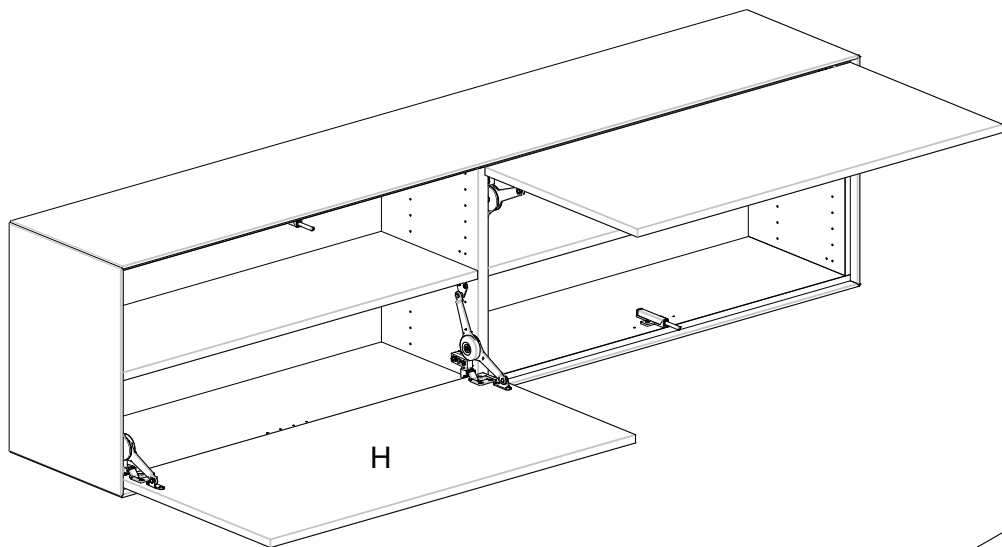

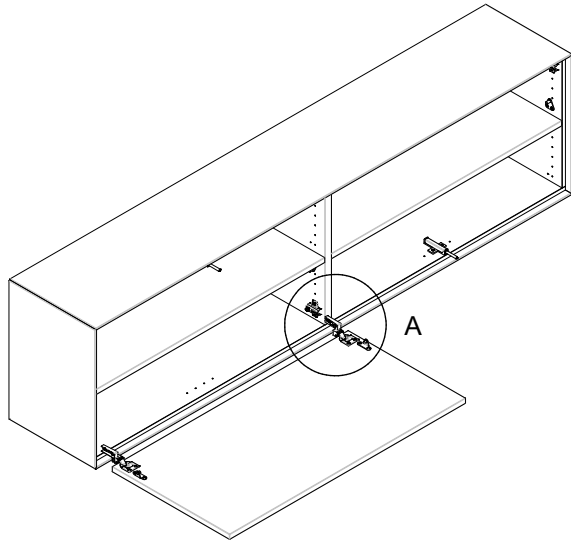

!

Lav klapp monteres på same måde.
Low flaps are mounted the same way
as illustrated with a high flap.
Alle Klappen werden in dieser Weise
montiert.
Liten lucka monteras på samma sätt.

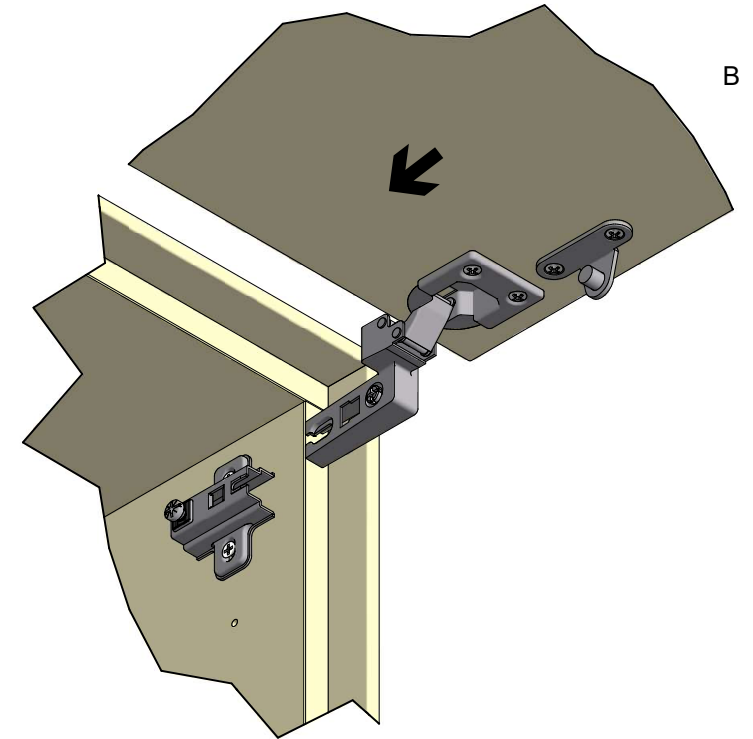
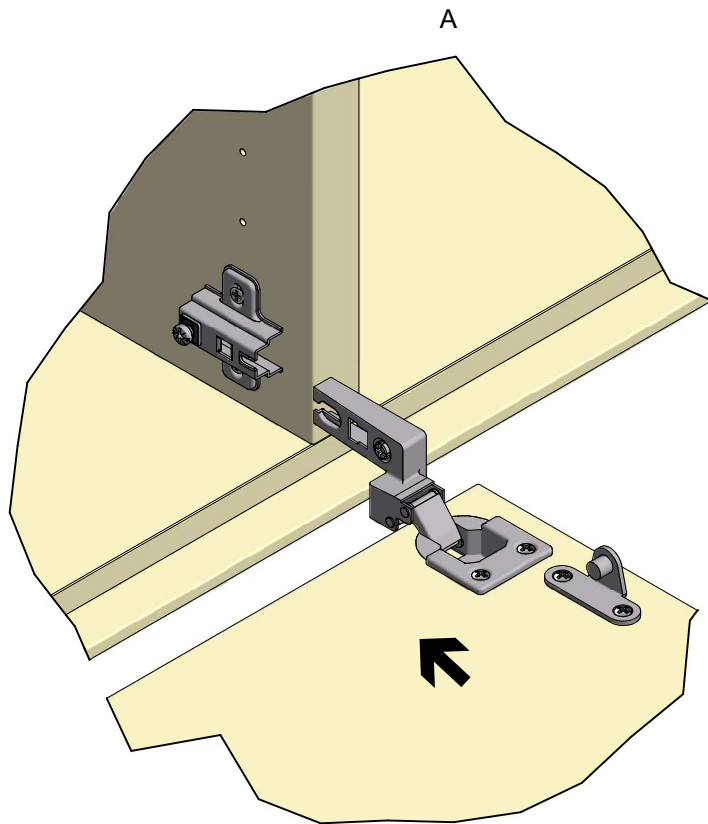
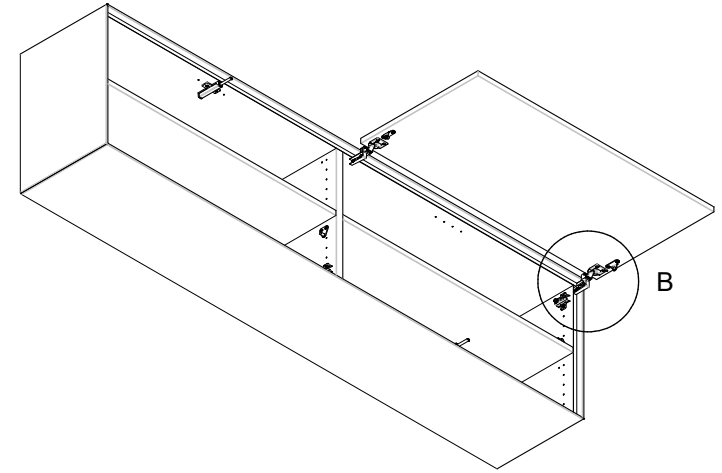

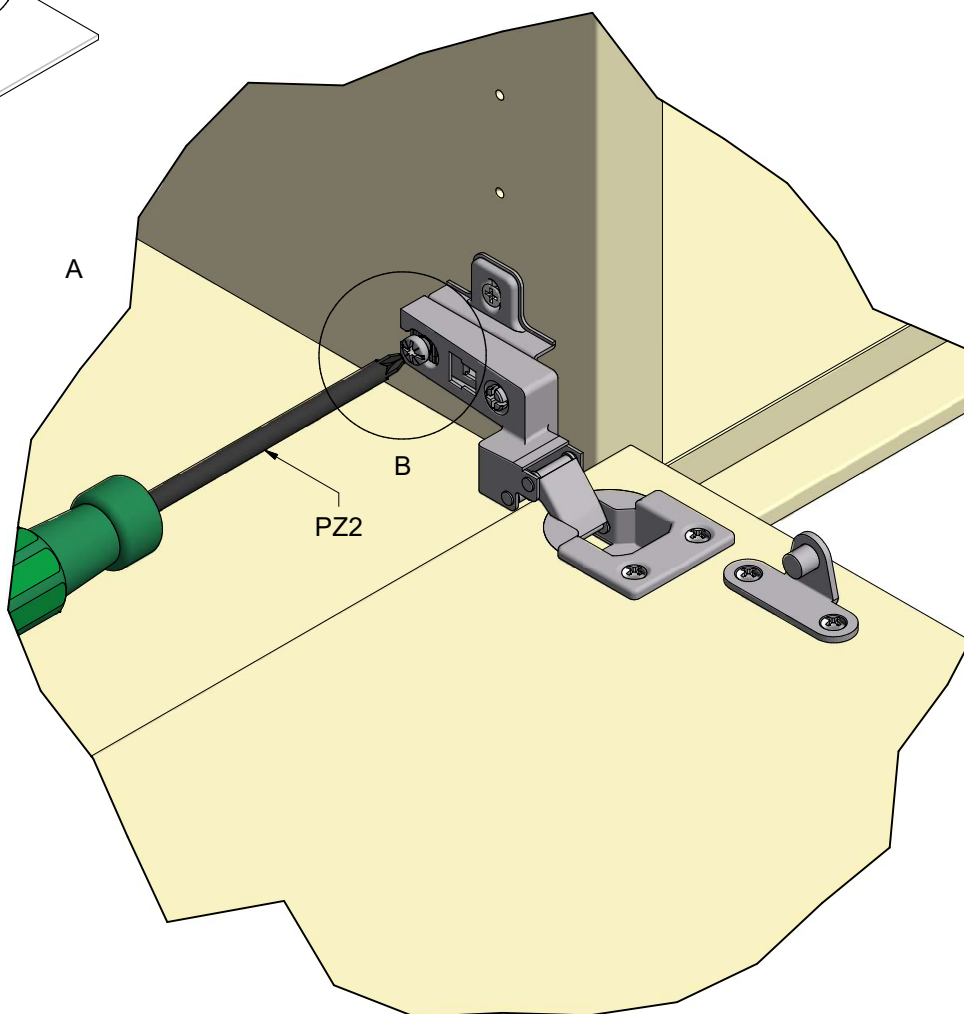
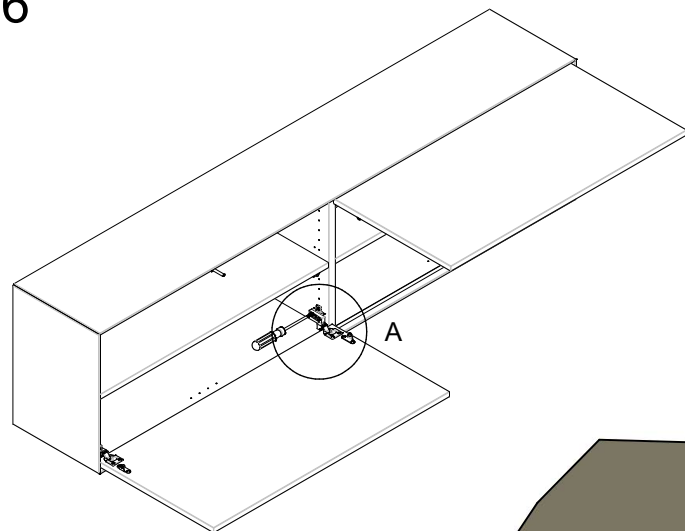

Alle hængsler fastskrues med PZ2 skruetrækker.
Use the PZ2 screwdriver to tighten the hinges.
Verwenden Sie den PZ2 Schraubendreher, um die
Scharniere festzuziehen.
Alla gångjärn monteras med PZ2 skruvmejsel
(stjärnskruvmejsel).

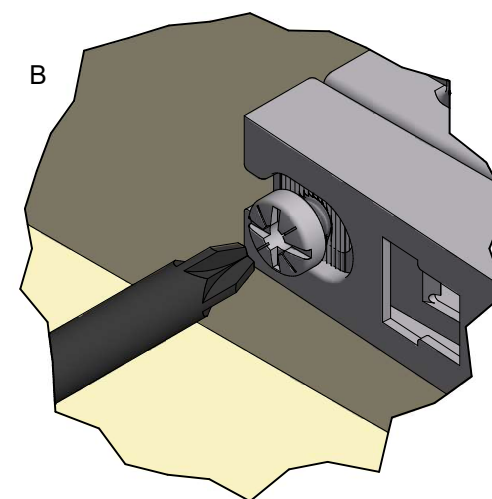

7

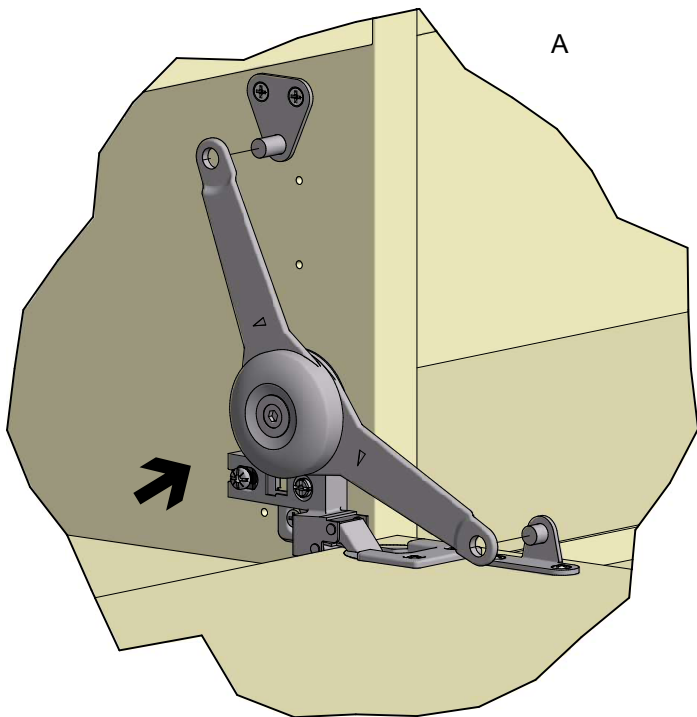
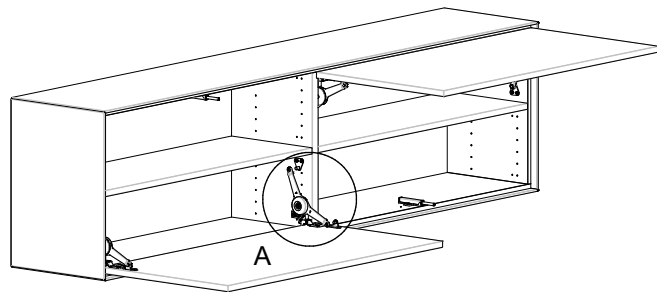

F8 beslag klikkes på plads.
Click the F8 bracket into place.
Der F8 Beschlag wird angeklickt.
F8 beslaget, gångjärnet klickas på plats.

40007-E3-P9 /11

8

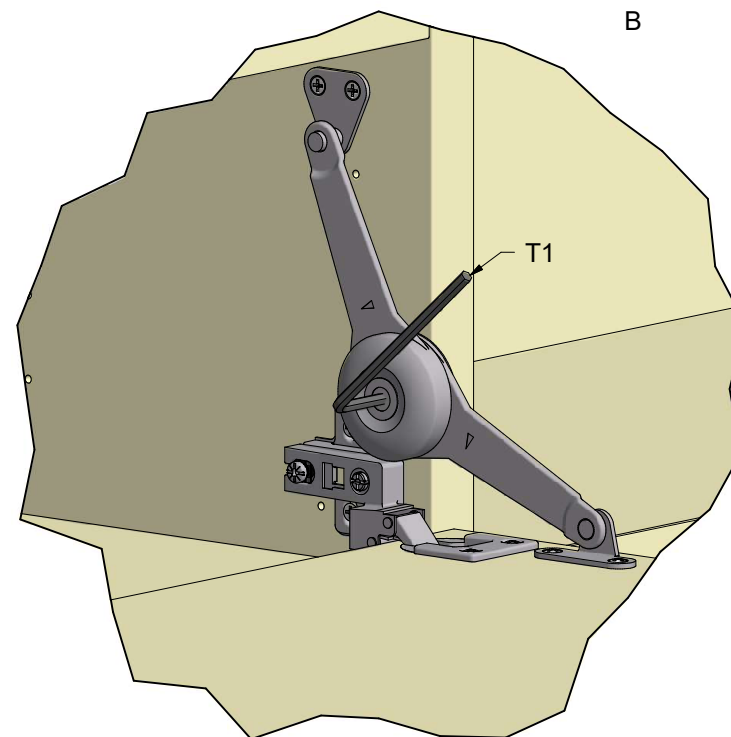
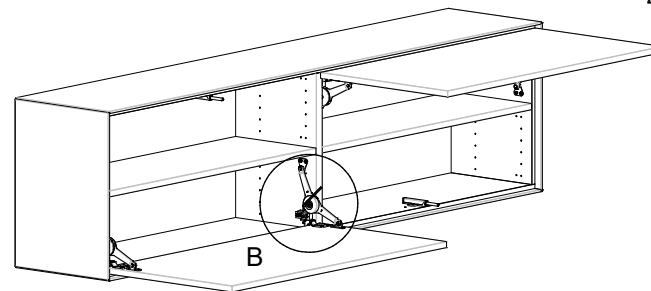

Friktion i F8 beslaget justeres med T1 nøgle.
Friction in the F8 bracket is adjusted with the T1 wrench.
Reibung in der F8 Beschlag wird mit ein T1-Schraubenschlüssel justiert.
Justera F8 beslaget med T1 nyckeln.

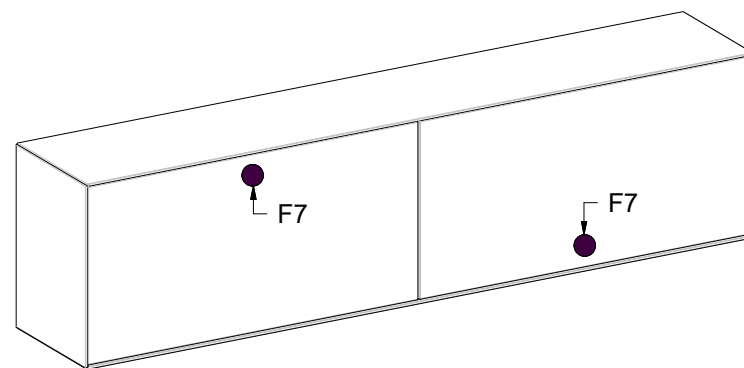
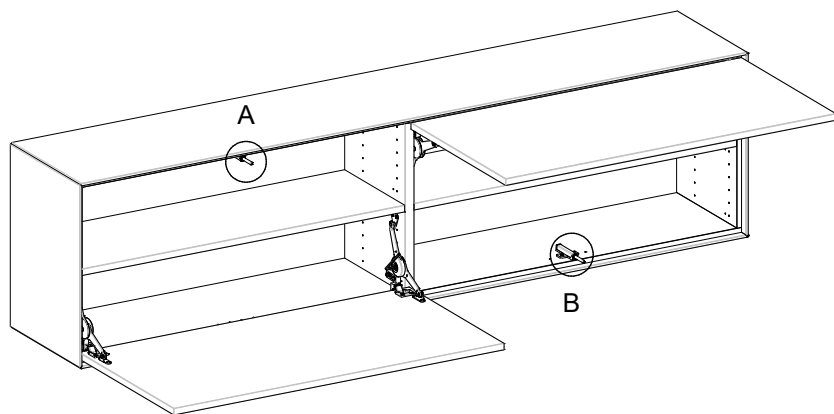

Når klappen lukkes skal der trykkes på det punkt, hvor F7 er placeret.
When the flap closes, press the point where the F7 is located.
Wenn die Klappe geschlossen wird, drücken Sie den Punkt, wo die F7 angeordnet ist.
När luckan stängs skall man trycka på punkten där F7 är markerad.

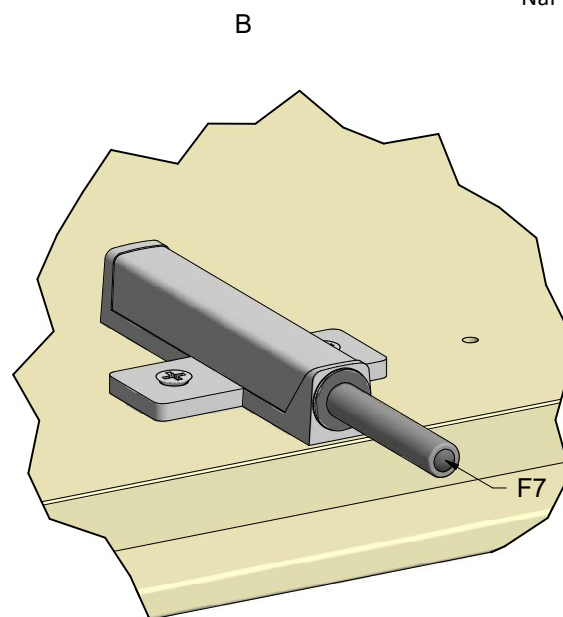
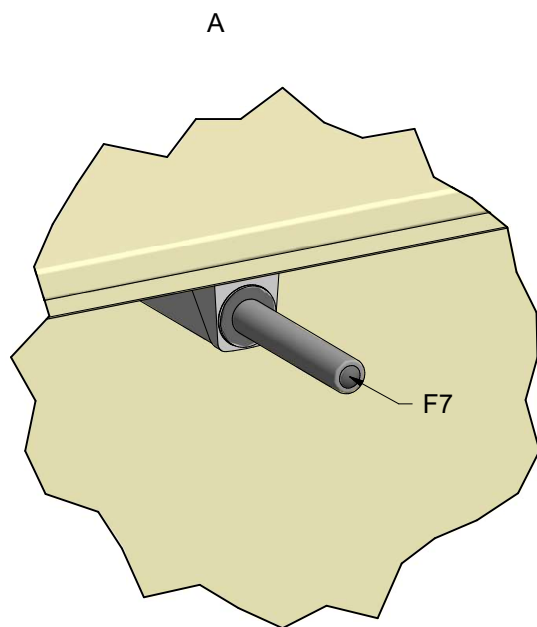

10

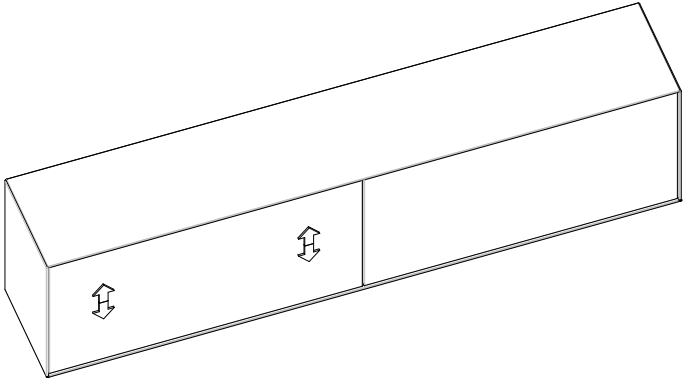
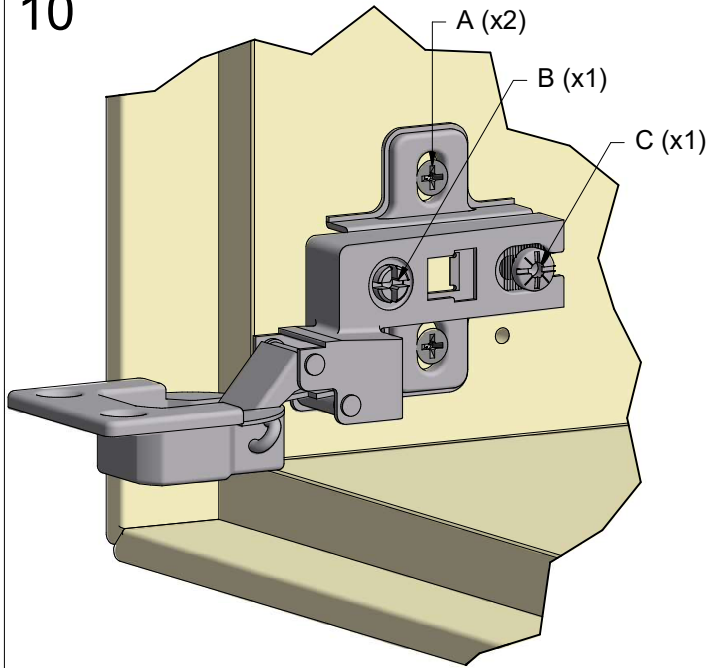

Højdejustering A (x2)
 Height adjustment A (x2)
 Höhenverstellung A (x2)
 Højjustering A (x2)

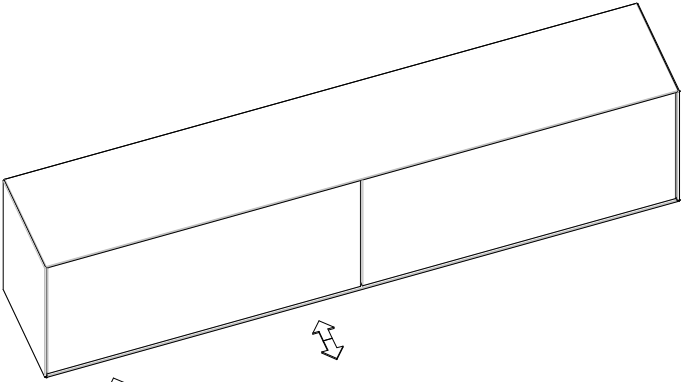
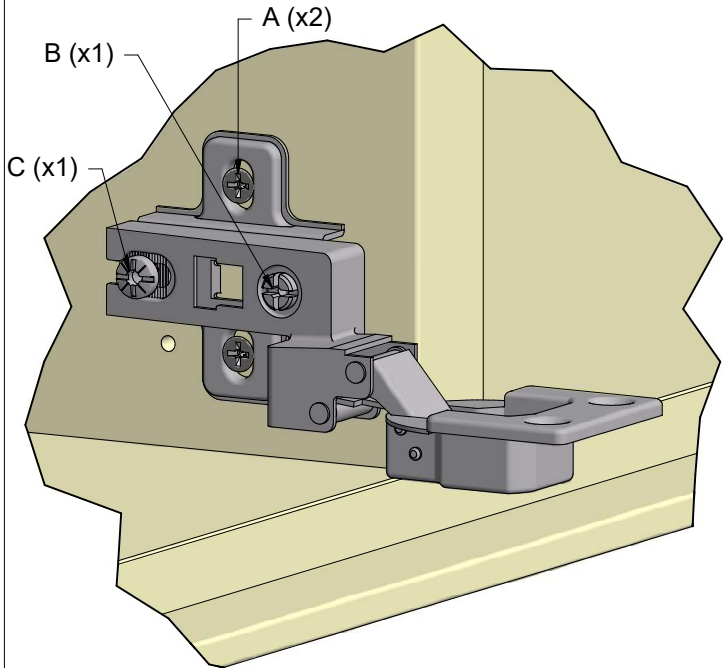

Dybdejustering C (x1)
 Dept adjustment C (x1)
 Tiefenverstellung C (x1)
 Djupjustering C (x1)

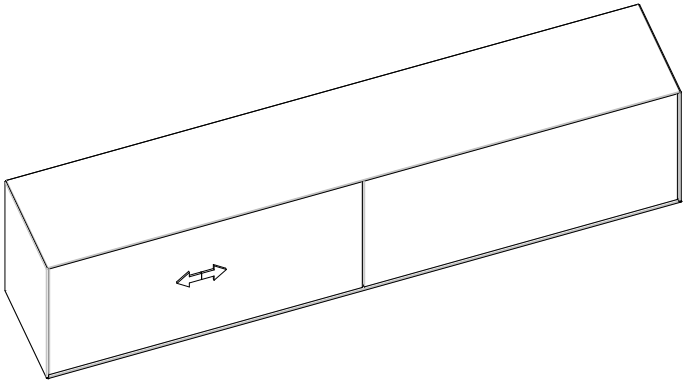

Sidejustering B (x1)
 Side adjustment B (x1)
 Seitenverstellung B (x1)
 Sidojustering B (x1)